

Grua taller

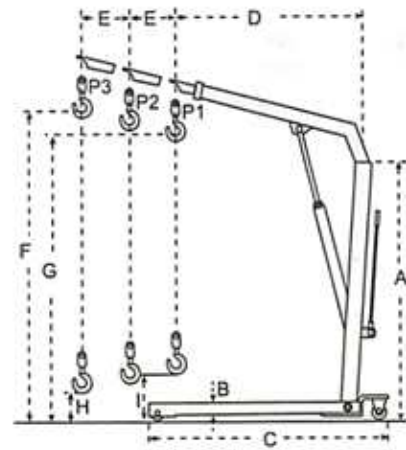

Modelo	Capacidad en posición			Dimensiones									Anchura total	Peso total
	kg			mm									Mm	kg
	P1	P2	P3	A	B	C	D	E	F	G	H	I		
SC500A	500	425	350	1350	165	1510	895	102	2150	1995	150	340	950	80
SC1000A	1000	800	700	1615	90	1630	1230	150	2500	2330	—	245	1120	115
SC2000A	200	1700	1500	1675	205	1900	1290	150	2705	2505	—	230	1165	165



SC500A



SC1000A



SC2000A

